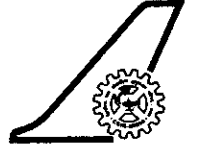


वैज्ञानिक तथा औद्योगिक अनुसंधान परिषद्  
Council of Scientific & Industrial Research  
राष्ट्रीय वांतरिक्ष प्रयोगशालाएं  
National Aerospace Laboratories



CSIR - NAL Estd. 1959  
ISO 9001 : 2015  
Certified Organization

Invitation for e-Bids / Notice Inviting e-Tender

Tender No. NAL/PUR/ACD/169/24(S)

Date: 05-Dec-2024

CSIR - National Aerospace Laboratories (NAL), Bengaluru, Republic of India, is one of the premier research laboratories under aegis of Council of Scientific and Industrial Research (CSIR), an autonomous body under the Department of Scientific and Industrial Research, Government of India, New Delhi. CSIR-NAL is a Science and Knowledge based Research, Development and Consulting Organization. It is internationally known for its excellence in Scientific Research in Aerospace Engineering.

The Director, CSIR-NAL invites e-bids from the Manufacturers, their distributors and Indian Agent of Foreign Principals, if any, for the procurement of the following Goods/Services for its day-to-day research

| Sr. No. | Tender No.            | Brief Description of material (s)   | Quantity | Type of Bid             | Mode of Procurement       |
|---------|-----------------------|---|----------|-------------------------|---------------------------|
| 1       | NAL/PUR/ACD/169/24(S) | Supply of Metal Tools for Wing AFT bottom access cover<br>(Details as per specification and qualification criteria) | 2 Set    | Single Stage Single Bid | Open Tender (Gem Bidding) |

- E-Bids are invited through the electronic tendering process and the Tender Document can be downloaded from the Government e-Marketplace Portal i.e., <https://gem.gov.in>. **The submission of e-Bids will be only through the GeM portal <https://gem.gov.in>. Bids will not be accepted in any other form.**
- Interested bidders' may obtain further information from the office of the:  
Stores & Purchase Officer  
Purchase Section  
CSIR- National Aerospace Laboratories  
PB No.1779, HAL Airport Road, Kodihalli, Bengaluru – 560017  
Karnataka-India  
Tel #: 080 25086040/6041/6044  
Fax #: 080 25269611  
Email : [purchasek@nal.res.in](mailto:purchasek@nal.res.in), [mkala@nal.res.in](mailto:mkala@nal.res.in)
- The prospective bidders' should adhere to deadlines specified in Tender details corresponding to this Tender on GeM portal <https://gem.gov.in>.
- Bid Security (BS) / Earnest Money Deposit (EMD):**  
The bidders has to furnish/submit BID SECURING DECLARATION as per the FORMAT. in the name of "**The Director, National Aerospace Laboratories, Bengaluru**", without which the bid is liable to be rejected.

पी बी सी. 1779, एचएएल एयरपोर्ट रोड, बेंगलूर- 560 017, भारत,

P B No 1779, HAL Airport Road, Bengaluru - 560 017, INDIA

फोन / Phone : ( का./ Off ) : +91 - 80 - 2508 6097 / 6710, फैक्स / FAX : +91-80-2526 9611



<http://www.nal.res.in>



[purchaseccadd@nal.res.in](mailto:purchaseccadd@nal.res.in)

5. The Schedule for Submission of e-Bids and Opening of e-Bids is as follows:

| Date & Time of Submission of e-Bid |            | Date and Time of Opening of e-Bid |            |
|------------------------------------|------------|-----------------------------------|------------|
| Date                               | Time (IST) | Date                              | Time (IST) |
| 31-Dec-2024                        | 11.00 am   | 31-Dec-2024                       | 11.30 am   |

6. **Open Tender enquiry:**

Only Local suppliers with prescribed local content as detailed in DIPPT Order No. P-45021/2/2017-PP (BE-II) dated 16<sup>th</sup> Sep, 2020 and subsequent orders issued by Ministry of Finance, Government of India from time to time, are eligible for bidding. bidders' must enclose the certificate declaring the local content of supplies as per the format.

7. **Global Tender Enquiry:**

Either the Indian Agent on behalf of the Foreign Principal or the Foreign Principal can bid directly in a tender but **not** both. However, the offer of the Indian Agent should also accompany the authorisation letter from their principal. To maintain sanctity of tendering system, one Indian Agent **cannot** represent **two** different foreign principals in one tender.

(a) In case of agents quoting in offshore procurements, on behalf of their principal manufacturers, one agent cannot represent two manufacturers or quote on their behalf in a particular tender enquiry.

One manufacturer can also authorize only one agent/ dealer. There can be only one bid from the following:

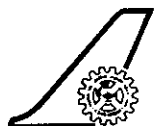
|     |   |
|-----|---|
| i)  | The Principal manufacturer directly or through one Indian agent on his behalf:<br>and |
| ii) | Indian/foreign agent on behalf of only one principal.                                 |

(b) Foreign bidders' must disclose the name and address of agent and representative in India and Indian bidders' must disclose their foreign principal or associates.

(c) If bidders' is Indian Agent of Foreign Principal, the following instruction shall be complied and as amended from time to time as on the date of issue of Tender:

|     |  |
|-----|--|
| i)  | Bidders' must necessarily comply with conditions of "Make in India" Order No.F-45021/2/2017-PP (BE-II) dated 16-Sep-2020 of Ministry of Commerce and Industry, Government of India, as amended from time to time on the date of issue of Tender.   |
| ii) | The bidders' shall comply with restrictions under Rule 144(xi) of the GFR 2017 related to restrictions on participation of Foreign bidders' and their Authorised Indian Agent/Dealer in terms of Order No.P-45021/112/2020-PP(BE-II) (E-43780) dated 24-Aug-2020 of the Ministry of Commerce and Industry, Department for Promotion of Industry and Internal Trade, as amended from time to time as on the date of issue of Order. |

**Note:** Kindly refer to the first page of Notice Inviting Tender for tender type/mode of procurement and submit the bid accordingly



## CSIR-National Aerospace Laboratories, Bengaluru-560 017, INDIA

9. The bids of those bidders' failing to comply the following clauses will be summarily rejected.
- (a) The bidders' proposing to supply finished products directly/indirectly from bidders' of Countries sharing the land border with India should submit copy of registration done with the Ministry of Home Affairs and Ministry of External Affairs.
  - (b) If the products supplied are not from bidders' of Countries sharing Land border with India, the bidders' should enclose a declaration
  - (c) The debarment of a bidders' in this tender, if any, is reciprocal of that Principal's Country, if it is Import.

**Note:** Kindly refer to the first page (NIT) for tender type (i.e. Open Tender Enquiry / Global Tender Enquiry) and submit your bid accordingly.

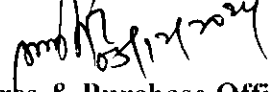
10. As per Govt. of India procurement policies,
- a) The purchaser intends to give purchase/service preference to local supplies (Preference to Make in India) in case the cost of procurement is up to Rs.50.00 (fifty) lakhs.
  - b) The procuring entity intends to give purchase/service preference to products/goods manufactured by micro, small and medium enterprises.
11. Bidders' are requested to refer to the instructions regarding Procurement Policies for "Make in India", issued by Ministry of Commerce and Industry, Department of Industrial Policy and Promotion dated. 28-May-2018, and 4-Jun-2020 and guidelines as and when issued.
12. Printed conditions, if any, submitted along with the quotation shall not be binding on us.
13. Bidders' to certify the quoted price is not higher than the price quoted with other Government Institution for similar specifications and quantity during the current financial year.
14. Payments shall be made promptly by the Purchaser but in no case later than thirty (30) days after submission of the invoice or claim by the Supplier. While claiming the payment, the supplier should certify in the bill/invoice that the payment being claimed strictly in terms of the contract and all obligations on the part of the supplier for claiming the payment have been fulfilled as required under the contract.

| <b>Mandatory fields in Tax Invoice and Receipt Vouchers</b> |   |
|---|---|
| Invoice Number and Date                                     | Name, address and GSTIN of the supplier                                 |
| Shipping and billing Address                                | Customer Name & GSTIN<br>[CSIR-NAL] Bank Details                        |
| HSN Code/SAC Code   | Place of Supply   |
| Taxable value and discounts                                 | Item details i.e. description, quantity (number), unit, the total value |
| Signature of the Supplier                                   | Rate and amount of taxes i.e. CGST/SGST/IGST                            |

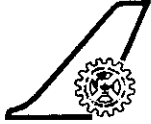
15. Kindly, note CSIR-NAL GST No.29AAATC2716R1ZB. The bidders' are requested to furnish their GST no. in their invoice, failing which NAL will not be able to make the timely payment.
16. Unsolicited / conditional / unsigned Quotations/Quotations received after the due date and time shall be summarily rejected. The bidders' shall comply the terms and conditions of the tender, failing which, the offer shall be liable for rejection.
17. The prospective bidders' are requested to refer to the Standard Terms and Conditions available on NAL Internet ([www.nal.res.in](http://www.nal.res.in)) under the icon 'Tender-Purchase' before formulating and submitting their bids'.
18. The Director, CSIR-National Aerospace Laboratories (NAL), Bengaluru, India reserves the right to accept or reject any bids or accept all tenders either in part or in full or to split the order, or to annul the bidding process without assigning any reasons there for.

Thanking you,

Yours faithfully



**Stores & Purchase Officer**  
**For and on behalf of CSIR-NAL**



**Specifications and Allied Technical Details for  
Supply of Metal Tools for Wing AFT Bottom Access Cover**

**1.1 End Use:**

Fabrication of aluminum tools for processing of composite components (In-board (IB) and out-board (OB) with AFT bottom access covers) of SARAS MkII aircraft under autoclave moulding conditions of 180°C to 200°C with external pressure of 7bar under full vacuum.

**1.2 Detailed Specifications**

Fabrication & supply of aluminium tools as per the following supplied drawings and CAD models listed below in Table 1. 3D CAD models in STP/IGS format and 2D drawing in PDF format/Hard printed copy will be provided to the successful bidder. However, sufficient information is provided in this document for estimation of the manufacturing cost of tools.

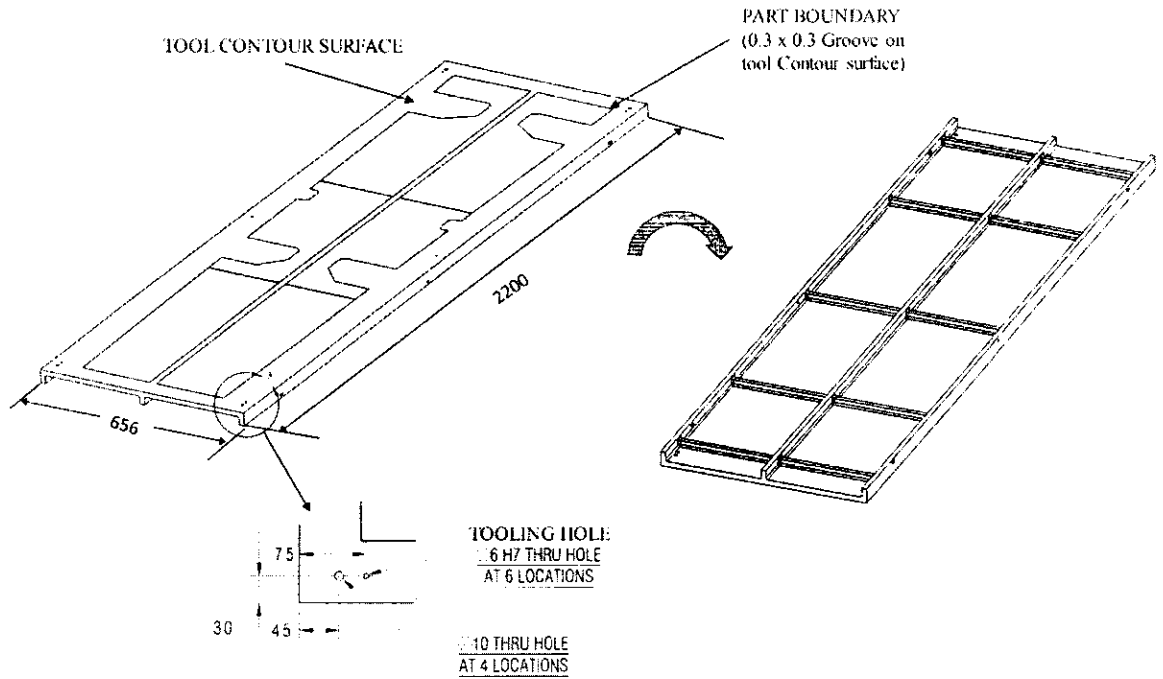
Bidder must quote for each serial number separately (mentioned in Table 1). These tools are not isolated in nature and bid price will be considered based on total cost and not individual item cost.

**Table 1: Tools details for fabrication and supply**

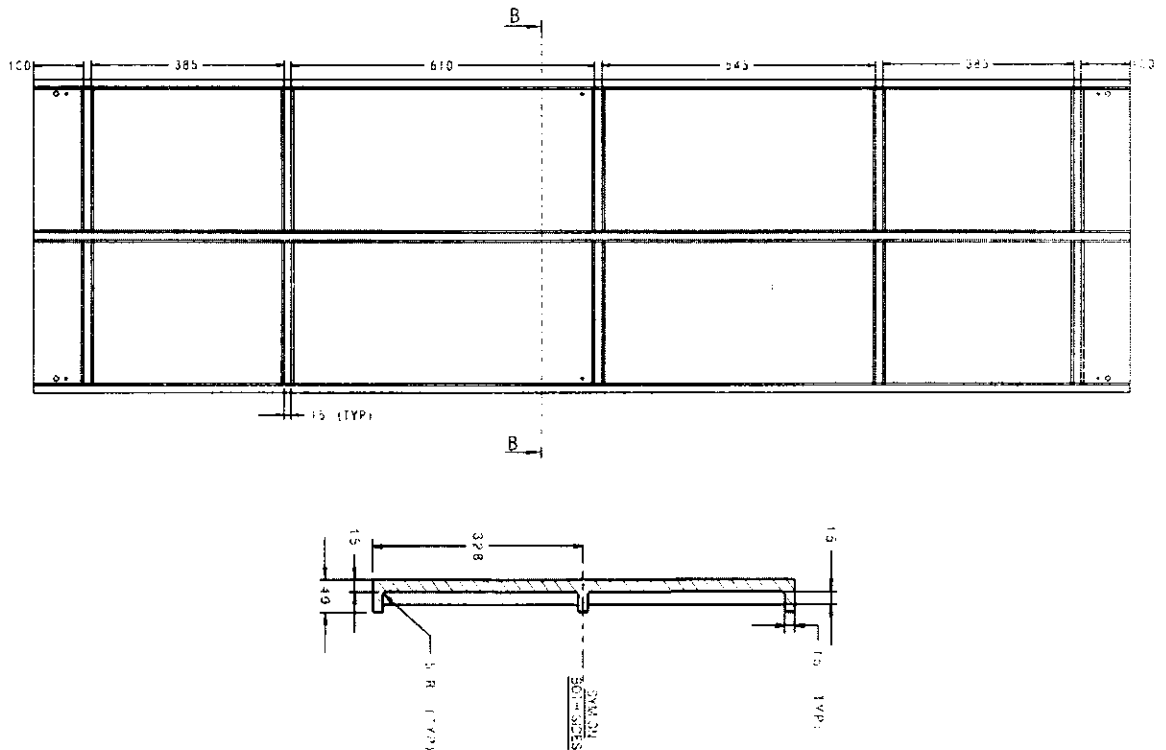
| <b>Sl. No.</b> | <b>Tool Name</b>  | <b>Drawing Number</b>    | <b>CADD Wt. (For Ref.)</b> | <b>Qty.</b> |
|----------------|---|--------------------------|----------------------------|-------------|
| 1              | Tool for wing AFT bottom access cover in-board (LH & RH)  | 25-A-T-57-50-000-031-000 | 68 Kg                      | 1 set       |
| 2              | Tool for wing AFT bottom access cover out-board (LH & RH) | 25-A-T-57-50-000-034-000 | 78 Kg                      | 1 set       |

Tool for wing AFT bottom access cover in-board (IB) and out-board (OB) along with their structural items are shown in Figure 1 to Figure 4 for ready reference. For actual size, dimensional tolerances, finish, treatment, etc., refer respective drawings. All dimensions mentioned are in 'mm'. However, sufficient information is given here for determining the manufacturing cost of the tools.

**A. Tool for Wing AFT Bottom Access Cover Inboard (LH & RH)**

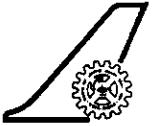


**Figure 1: Isometric view of access cover in-board (LH & RH) tool**

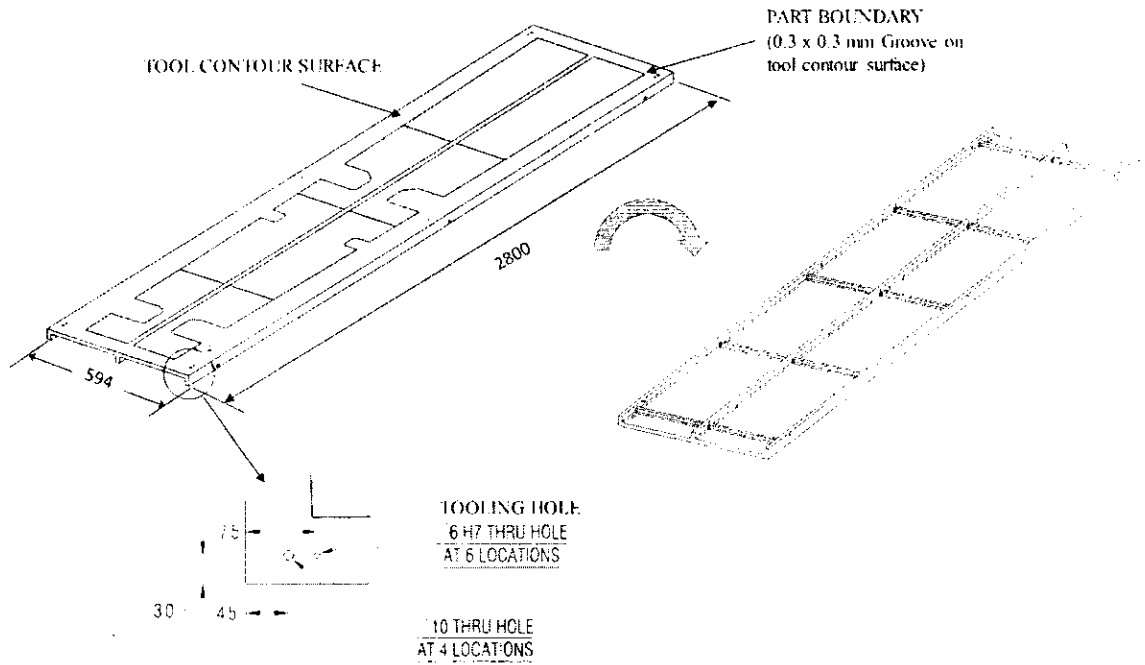


**SECTION BB (View rotated by 90° clock wise)**

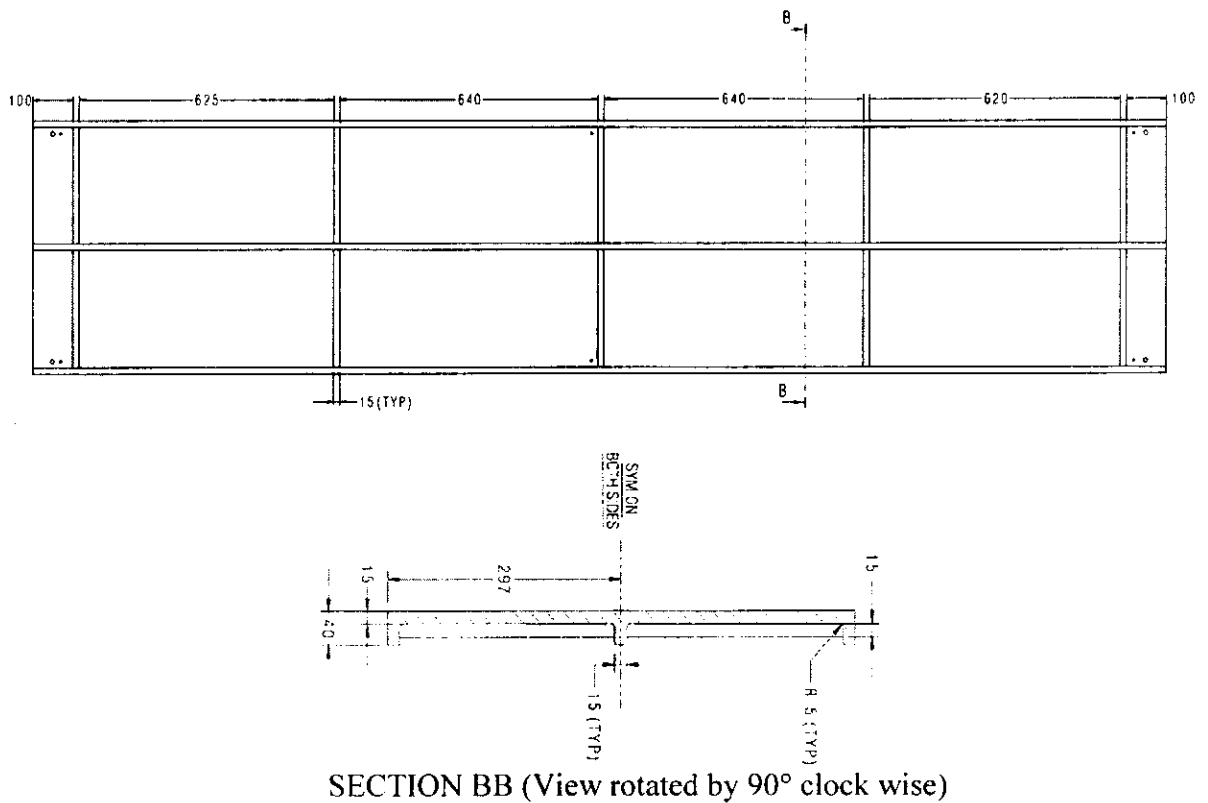
**Figure 2: Other views & dimensional details of access cover in-board (LH & RH) tool**



**B. Tool for Wing AFT Bottom Access Cover Outboard (LH & RH)**



**Figure 3: Isometric view of access cover out-board (LH & RH) tool**



**Figure 4: Other views & dimensional details of access cover out-board (LH & RH) tool**

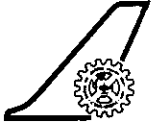
### 1.2.1. General instructions

- i. Machining of the tool contour surface, tooling holes, OTP holes have to be done in a single setting. Bidder may add additional references for machining purpose, and these references to be removed once tooling holes, OTP holes are established in the tool as per CAD model.
- ii. Tool material and build quality requirements has to meet the requirements mentioned against each item as per the drawing(s).
- iii. Material for tools is aluminum alloy of HE 30 6082 T6 or equivalent grade. For all other items such as bushes, bolts, etc., as specified in the drawing. The NDT to be carried out by NDT-II level/higher qualified inspector wherever required.
- iv. Use single block for machining of tools. No weld joints are permitted in the contour region.
- v. Datum reference pads for machining is provided. Additional pads may be added if required.
- vi. Machining of contour, tooling hole, OTP holes to be done using single reference.
- vii. Rough machining to be done on the tool contour surface plate keeping 1-2mm stock for further machining. At this stage complete tool to be stress relieved before final machining. Bidder may carry out additional stress relieving for fabrication of tool if required.
- viii. Typical stress relieve cycle of 300°C for 3hrs with heat-up /cooling rate of 1°C per min may be followed.
- ix. Bidder to submit the material and method adopted for fabrication of tools along with the bid.
- x. Tooling holes coordinates have to be engraved legibly and labelled at the non-working area of tool at the respective locations.
- xi. Contour to be machined to 2 triangle ( $\nabla\nabla$ ) surface finish standard.
- xii. Anodizing to be done for the tools to prevent oxidation /rusting of the tools.
- xiii. The tolerance for the tool to be followed as

| Item                                      | Tolerance Type       | Tolerance Value (mm) |
|---|----------------------|----------------------|
| Tooling /OTP holes w.r.t CAD model        | Positional tolerance | ±0.1                 |
| Tool contour w.r.t CAD model              |                      | ±0.5                 |
| Part boundaries, station lines & ML lines |                      | ±0.5                 |

- xiv. The contour inspections have to be carried out using tooling holes w.r.t CAD model at minimum of every 50mm grid location in the X and Y directions (along length and width of tool). Closer readings to be taken on need basis. Bidder to carry out inspection using CMM / Laser scanning method for the tools. The CMM / Laser equipment/s





should be calibrated and should have required validity for period of inspection. An individual report to be prepared for individual tools.

- xv. Part boundary, cutout boundaries, any other reference line and layer orientation lines have to be grooved to V-shape of about 0.3mm depth with 60° angle.
- xvi. The initial tool inspection (contour, boundary lines, OPT hole location etc.) will be done w.r.t to tooling hole. Later the tool inspection will be done using established OTP's.
- xvii. Bidder to provide point wise compliance showing both the additional features offered and the requirements that cannot be met.
- xviii. The step by step process sheet (Quality Assurance Plan) for manufacturing of tools to be submitted to NAL for record purpose. NAL may provide some change. Though NAL has accepted /modified the manufacturing process document, bidder is solely responsible for build quality of tools and qualifying the tools as per model / drawing requirement. The complete responsibility of supply of tools as per requirements specified in drawing and in this document lies with bidder and not with NAL.

**1.2.2 List of Deliverables:**

| Sl. No.                                   | Item Description   | Unit | Quantity |
|---|--|------|----------|
| <b>A. Tools and accessories:</b>          |  |      |          |
| 1.  | Tool for wing top skin I/B (LH+RH) as per drawing  | No.  | 1        |
| 2.  | Tool for wing top skin O/B (LH+RH) as per drawing  | No.  | 1        |
| <b>B. Documents / CAD data / Reports:</b> |  |      |          |
| 1.  | Manufacturing process document / quality assurance plan document with signature and seal for each operation duly coordinated by quality control department   |      |          |
| 2.  | NDT reports of material used to ensure crack/defect free material with signature and seal  |      |          |
| 3.  | Raw material CoA/CoC, along with NABL certificate for chemical composition   |      |          |
| 4.  | Stress relieving with signature and seal   |      |          |
| 5.  | Heat treatment (bushes, inserts etc.) report with signature and seal   |      |          |
| 6.  | Calibration report of CMM/ Laser equipment used for inspection of tools<br>Dimensional and CMM/ Laser tracker report of tools as per supplied drawing with signature and seal duly coordinated by quality control department |      |          |
| 7.  | Anodizing certificate with signature and seal for tools  |      |          |
| 8.  | As built tool 3D CAD model and 2D drawing in case of changes made at supplier and released by supplier   |      |          |

### 1.4.3 Pre-Dispatch Inspection

NAL personnel may visit at different stages of manufacturing (mentioned below) of tools, at supplier's place or at other place where work is in progress.

- i. After rough machining of blocks
- ii. During stress relieving
- iii. During contour machining
- iv. During contour inspection

|    |                                   |   |
|----|-----------------------------------|---|
| 1) | Location                          | At vender location  |
| 2) | Number of persons                 | 02  |
| 3) | Period of pre-dispatch Inspection | 4-6 days depending on the requirement   |
| 4) | Nature of pre-dispatch Inspection | a) Tool contour and dimensional inspection<br>b) Review of machining and stress relieving process |

**Note:**

- i. *Travel expenses of CSIR-NAL personnel for pre-dispatch will be borne by CSIR-NAL.*
- ii. *Supplier to share complete inspection report prior to pre-dispatch inspection including raw material CoC, NDT to ensuring no cracks and stress relieving/heat treatment certificate*

### 1.4.5 Acceptance Test of Tools

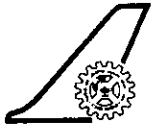
**The acceptance tests plan (ATP) at the final destination (NAL) include the following:**

1.4.5.1. Tool should meet all the requirements mentioned in the drawing/s and the requirements mentioned in this document.

**The acceptance tests at the final destination (NAL) include the following:**

- a) Tool NMG/surface Contour and Dimensional measurements, checks and Inspection as per the supplied drawings. Deviations if any, to be corrected by bidder without any additional costs to NAL.
- b) Vacuum Integrity and leak test: Tools will be subjected for heating cycle (180°C for 2 hours under full vacuum and 7bar pressure) to check for vacuum leaks. Vacuum leaks if any, bidder need to correct the tools without any additional costs to NAL.
- c) Functionality checks on  
Anodizing to withstand operating condition: 180°C for 2 hours.

1.4.5.1.1. After subjecting the tools to cure cycle, Laser tracker inspection of all the tools will be carried out by CSIR-NAL as per the drawing at no cost to bidder. Also, the visual and dimensional inspection of the tool will be carried out at per drawing by CSIR-NAL. at no cost to bidder.



## CSIR-National Aerospace Laboratories, Bengaluru-560 017, INDIA

1.4.5.1.2. If any deviation is found in tool NMG/surface contour and dimensional measurements, checks as per the supplied drawings after inspection, these deviations /s have to be corrected by supplier without any additional costs to NAL.

1.4.5.1.3. After the cure, the tool should not have any other visible deterioration. If found, bidder should rectify the tools without any additional charge to CSIR-NAL.

### 1.5 Warranty of Tools

- On site Comprehensive Warranty: 1 year from the date of acceptance

### 1.7 Delivery Schedule (including supply & acceptance)

| Delivery of the item   |                        | Acceptance of the item                        |
|--|------------------------|---|
| Days/<br>Weeks/ Months<br>From the date of<br>Purchase Order | Location               | Days/ Weeks/Months<br>from the date of supply |
| 3 months   | CSIR-NAL,<br>Bengaluru | 10 Days                                       |

## **Qualification Requirements Eligibility & Qualification Requirements**

### **1.1 Eligibility Criteria**

#### **a) Legal Valid Entity:**

The Bidder shall necessarily be a legally valid entity either in the form of a Limited Company or a Private Limited Company registered under the Indian Companies Act, 1956 or Country of Origin.

Bidder may be Joint Venture, Consortium or Association so long as they are formed and registered prior to the bid submission date.

#### **b) Financial qualification criteria:**

The average annual financial turnover of 'The bidder' during the last three financial years, should be at least **Rs. 50 Lakhs** as per the annual report. Bidder to submit the audited balance sheet and profit & loss account statement for last three years.

### **1.2 Technical Qualification Criteria**

#### **Criteria 1 - Experience and Past Performance:**

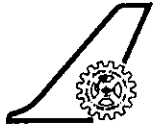
- a) The bidder should have regularly for at least the last 05 years, ending 31st March of the previous financial year manufactured and supplied Metal (steel / Aluminum) Tools having similar accuracy mentioned in Specification (Annexure-1) with similar or better material with the tolerances specified.
- b) 'The bidder' should have manufactured and supplied **at least 5 numbers** of similar metal tools as specified in specification (Annexure-1) in the last five years (at least one tool in one year). Bidder to submit the details of the tools manufactured along with customer purchase order as an evidence.

#### **Criteria 2 - Capability- Equipment & manufacturing Facilities:**

Bidder must have in his premises the required CNC machine (minimum 3m bed size) for machining of the tools. Bidder to provide the CNC machine details along with their calibration report.

'The bidder' must have an annual capacity to manufacture and supply (/erected/ commissioned) at least 5 nos. of similar metal tools.

The bidder should have valid ISO 9001-2015/AS9100:2016 certification for the manufacturing facility to be used the purpose of this tender. In case the work like contour machining, stress relieving etc., is outsourced by the bidder, the outsourced partner also should have valid ISO 9001-2015/AS9100:2016 certification for the respective operation/s. Bidder to submit the ISO 9001-2015/AS9100:2016 certificate.



**Tender No.: NAL/PUR/ACD/169/24**

**BID-SECURING DECLARATION FORM**

Date: \_\_\_\_\_

Bid No. \_\_\_\_\_

Name and complete name and address of the purchaser

I/We. The undersigned, declare that:

I/We understand that, according to your conditions, bids must be supported by a Bid Securing Declaration.

I/We accept that I/We may be disqualified from bidding for any contract with you for a period of one year from the date of notification if I am /We are in a breach of any obligation under the bid conditions, because I/We

|     |  |
|-----|--|
| (a) | have withdrawn/modified/amended, impairs or derogates from the tender, my/our Bid during the period of bid validity specified in the form of Bid; or   |
| (b) | having been notified of the acceptance of our Bid by the purchaser during the period of bid validity<br><br>(i) fail or reuse to execute the contract, if required, or<br><br>(ii) fail or refuse to furnish the Performance Security, in accordance with the Instructions to Bidders. |

I/We understand this Bid Securing Declaration shall cease to be valid if I am/we are not the successful Bidder, upon the earlier of (i) the receipt of your notification of the name of the successful Bidder; or (ii) thirty days after the expiration of the validity of my/our Bid.

Signed: (insert signature of person whose name and capacity are shown)  
in the capacity of (insert legal capacity of person signing the Bid Securing Declaration).

Name: (insert complete name of person signing the Bid Securing Declaration)

Duly authorized to sign the bid for an on behalf of : (insert complete name of Bidder)

Dated on \_\_\_\_\_ day of \_\_\_\_\_ (insert date of signing)

Corporate Seal (where appropriate)

(Note: In case of a Joint Venture, the Bid Securing Declaration must be in the name of all partners to the Joint Venture that submit the Bid)

**Tender No.: NAL/PUR/ACD/169/24**

**SELF DECLARATION CERTIFICATE FOR LOCAL CONTENT**

In Respect of NIT/RFQ No. ....issued by CSIR-National Aerospace Laboratories, Bengaluru

I, the undersigned, ..... (full names), do hereby declare, in my capacity as ..... of .....(name of bidder / OEM), the following:

(a) The facts contained herein are within my own personal knowledge.

(b) I have read and understood the requirement of Local Content and same is specified as percentage calculated in accordance with the definition provided at clause 2 of revised **Public Procurement (Preference to Make in India) Order 2017**.

*"Local content" as per above order means the amount of value added in India which shall be the total value of items procured (excluding net domestic indirect taxes) minus the value of imported content in the item (including all customs duties) as a proportion of the total value in percent."*

(c) I have satisfied myself that the goods/services/works to be delivered in terms of the above-specified NIT comply with the local content requirements and I hereby confirm in respect of quoted item(s) that:

(i) Local Content is equal to ----- (in percentage) and come under 'Class-I Local Supplier Category' (The local content requirement to categorize a supplier as Class I Local Supplier is minimum 50%)  
Or

(i) Local Content is equal to ----- (in percentage) and come under 'Class-II Local Supplier Category' (The local content requirement to categorize a supplier as Class II Local Supplier is minimum 20%)

(Tick appropriate Category of Local Supplier).

(d) The local content calculated using the definition given above are as under:

| Sl. No | Name of Item / Equipment | Local content calculated as above (%) | Location of local value addition (Location shall be the specified as name of city or district, etc.) | Imported content including all Customs duties (%) |
|--------|--------------------------|---------------------------------------|--|---|
|        |                          |                                       |  |   |

Note: Attach separate sheet duly signed if space is not sufficient.

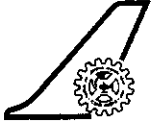
(e) I understand that if we are offering products with local content less than the minimum requirement prescribed under Clause 5 of the above order, we will fall under the category of Non-Local Suppliers. We can't claim ourselves as Class-I local suppliers/ Class-II local suppliers by claiming the services such as transportation, insurance, installation, commissioning, training and after sales service support like AMC/CMC etc. as local value addition.

(f) I also understand; false declarations will be in breach of the code of integrity under rule 175(1)(i)(h) of the General Financial Rules for which a bidder or its successors can be debarred for up to two years as per Rule 151(iii) of the General Financial Rules along with such other actions as may be permissible under law.

**SIGNATURE:**  
Seal / Stamp

**DATE:** \_\_\_\_\_

NB:



## **CSIR-National Aerospace Laboratories, Bengaluru-560 017, INDIA**

- (i) Before completing this declaration, bidders must study the General Conditions, Definitions, Government Directives applicable in respect of Local Content & prescribed tender conditions.
- (ii) In case the bidder is supplier and not OEM, then the above mentioned MII certificate should be given by the OEM in their letter head.
- (iii) Local content percentage shall be declared item wise or tender wise strictly as per the terms of the tender.
- (iv) Local Content Declaration to be signed by Chief Financial Officer or other Legally Responsible Person Nominated in Writing by The Chief Executive or Senior Member/Person with Management Responsibility (Corporation, Partnership or Individual).
- (v) The obligation to complete, duly sign and submit this declaration cannot be transferred to an external authorized representative, auditor or any other third party acting on behalf of the bidder.

Tender No.: NAL/PUR/ACD/169/24

**Format for declaration by the Bidder for Code of Integrity & Conflict of Interest (This declaration should be furnished on the Bidders Letter Head**

Ref. No: \_\_\_\_\_

Date \_\_\_\_\_

To,

\_\_\_\_\_

\_\_\_\_\_  
(Name & address of the Purchaser)

Sir/Madam,

With reference to your Tender No. \_\_\_\_\_ dated \_\_\_\_\_ I/We hereby declare that we shall abide by the Code of Integrity for Public Procurement as mentioned under Para 1.3.0 of ITB of your Tender document and have no Conflict of Interest.

The details of any previous transgressions of the Code of Integrity with any entity in any country during the last three years or of being debarred by any other Procuring Entity are as under:

- a)
- b)
- c)

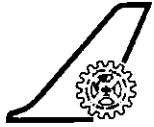
We undertake that we shall be liable for any punitive action in case of transgression/contravention of this code.

Thanking you,

Yours Sincerely,

Signature  
(Name of the Authorised Signatory)  
Company Seal





## CSIR-National Aerospace Laboratories, Bengaluru-560 017, INDIA

Tender No.: NAL/PUR/ACD/169/24

### SELF CERTIFICATION

With reference to Clause No. 1.1.3, of this tender and GoI, Ministry of Finance Order No.: F. No. 6/18/2019-PPD, dated 23rd July, 2020, on "Restrictions under Rule 144 (xi), of the General Financial Rules (GFRs)", & OM No. F. No. 18/37/2020-PPD, dated 8<sup>th</sup> February, 2021, and as amended from time to time on the date of issue of Tender:

It is certified that

- We are not a bidder of a country which shares a land border with India.

OR

- We are a bidder of a country which shares a land border with India, however, we are eligible to bid in any procurement whether of goods or services as we are registered with the Competent Authority as specified in Ministry of Finance (GoI) Order No. 6/18/2019 – PPD, dated 23rd July 2020. Copy of valid registration is attached.
- Tick as applicable

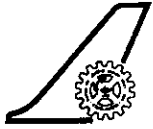
Place:

Date:

Authorised Signatory Name:  
Company Seal

### TERMS & CONDITIONS

| Tender No. |   |   |
|------------|---|---|
| Sr. No.    | Approximate weight of the Consignment   | Approximate dimensions of the consignment |
| 1          |   |   |
| 2          | Indian Customs Tariff No. and HSN No.<br>(ICT & HSN No.)  |   |
| 3          | Country of Origin   |   |
| 4          | Percentage of Local Content   |   |
| 5          | Annual Turnover   |   |
| 6          | Type of Supplier  |   |
| 7          | Mode of Shipment<br>By Air / SEA / Road / e-download  |   |
| 8          | <b>Port of Destination</b>  | <b>Final Destination</b>                  |
| 9          | Delivery Term (INCO Term), as the case may be   |   |
| 10         | Delivery Schedule including Supply, Installation, Commissioning, Training & Acceptance  |   |
| a)         | Delivery of the Item BoQ/NIT<br>[In weeks / Days / Months]<br>from the date of PO / LC / ILC / Advance<br><b>[Mention the appropriate term]</b> |   |
| b)         | Installation & Commissioning from the date of Delivery of item<br>[In weeks/Days/Months]  |   |
| c)         | Training from the date of Installation & Commissioning of item<br>[In weeks/Days/Months]  |   |
| d)         | Acceptance from the date of Training<br>[In weeks/Days/Months]  |   |



**CSIR-National Aerospace Laboratories, Bengaluru-560 017, INDIA**

|    |   |  |
|----|---|--|
| 11 | Installation & Commissioning (if any)<br>Quoted Price inclusive or exclusive  |  |
| 12 | Training (if any)<br>Quoted Price inclusive or exclusive  |  |
| 13 | Partial Shipment<br>[If partial shipment required, the charges incurred towards partial shipment to be borne by Bidder] |  |
| 14 | Payment Term  |  |
| 15 | Currency of Bid/Quotation   |  |
| 16 | Statutory Levies<br>[GST/IGST or any other taxes, duties]<br>% of tax to be mentioned.                                  |  |
| 17 | Bidder GST No.  |  |
| 18 | Bidder Bank Details along with Canceled cheque  |  |
| 19 | Insurance Coverage  |  |
| 20 | Warranty  |  |
| 21 | Agree to submit Performance Security, if any  |  |

|              |  |  |
|--------------|--|--|
| 23           | Validity of offer  |  |
| 24           | Order to be placed<br>[Full address, Tel #, Fax #, Email Id,<br>Contact Person]  |  |
| 25           | Nature of the item <b>[to be specified]</b><br><br>Hazardous/Radio Active/ Perishable/<br>Dangerous/ Shelf-life or any other       |  |
| 26           | Bidder to mention in the quote, any<br>special carrier requirement is<br>necessary for transport viz Special<br>License, ODC etc., |  |
| 27           | Any other  |  |
| 28           | Total Price quoted as per BoQ/Price<br>Schedule/List of Deliverables<br>exclusive of tax   |  |
| 29           | Total Price quoted as per BoQ/Price<br>Schedule/List of Deliverables<br>inclusive of tax   |  |
| <b>Note:</b> | <b>Unit Price indicating currency FOB (named port of shipment or FCA<br/>(named place of delivery)</b>                             |  |